

Data Sheet

HF Reader System Series 6000 S6700 Multi-Protocol Transceiver IC

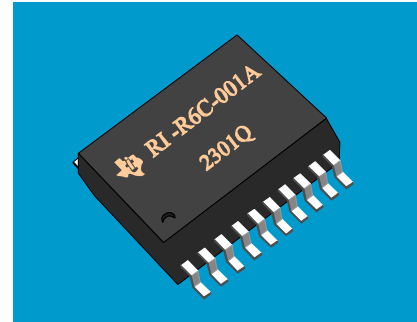

Specifications:

Part number	RI-R6C-001A
Operating Frequency	13.56MHz
Supported RF Communication Protocols	<ul style="list-style-type: none"> - Tag-it HF - ISO 15693-2 (e.g. Tag-it HF-I) - ISO 14443-2 (Mode A) - Transparent (directly switched according to input pin)
Operating Voltage	3.3V - 5V DC \pm 10%
Current Consumption	Transmit: < 200 mA Stand-by: - Oscillator on < 5 mA - Oscillator off < 50 μ A
Transmitter power	200mW at 5V DC operating voltage
Transmitter modulation	ASK, 10% to 100% selectable through external components
Antenna Impedance	50 Ohm at 13.56MHz
Receive channels	ASK 423.75kHz, ASK 847kHz, FSK 423.75kHz/484.29kHz selectable
Communication Interface	Serial interface, CMOS compatible
Operating Temperature	-40°C to +85°C
Storage Temperature	-55°C to +125°C
Package / Pincount	SSOP 20

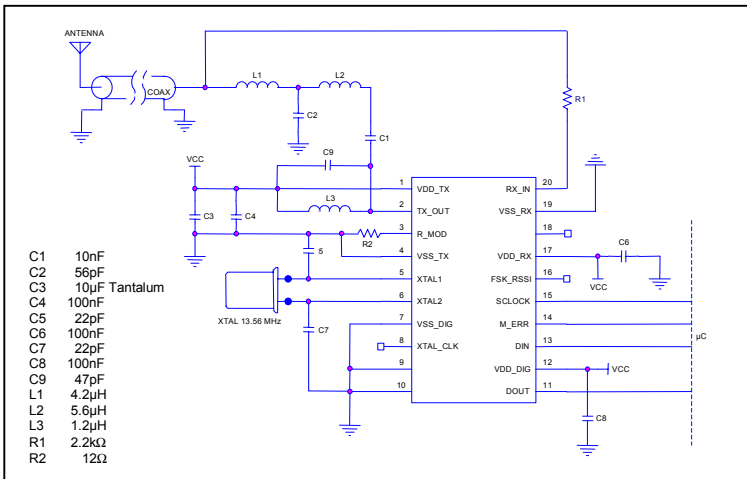

Recommended application schematic

Pin description

Pin	Symbol	Description
1	VDD_TX	Transmitter power supply
2	TX_OUT	Output transistor drain connection
3	R_MOD	External resistor to set 10% modulation depth
4	VSS_TC	Transmitter section ground
5	XTAL1	Pin 1 of Xtal resonator, external clock input
6	XTAL2	Pin 2 of Xtal resonator
7	VSS_DIG	Digital section ground
8	XTAL_CLK	Buffered output of Xtal oscillator
9	Not used	To be grounded for normal operation
10	Not used	To be grounded for normal operation
11	DOUT	Data output for serial link
12	VDD_DIG	Digital section power supply
13	DIN	Data input for serial link
14	M_ERR	Manchester Protocol error flag
15	SCLOCK	Serial link clock
16	FSK_RSSI	FSK or RSSI signal output
17	VDD_RX	Receiver section power supply
18	Not used	To be left open for normal operation
19	VSS_RX	Receiver section ground
20	RX_IN	Receiver input

For more information, contact the sales office or distributor nearest you. This contact information can be found on our web site at: <http://www.ti-rfid.com>

Texas Instruments reserves the right to change its products and services at any time without notice. TI provides customer assistance in various technical areas, but does not have full access to data concerning the uses and applications of customers products. Therefore, TI assumes no responsibility for customer product design or for infringement of patents and/or the rights of third parties, which may result from assistance provided by TI.